



Imprint

Publisher:

speedART - eine Marke der DESIGNTEC e.K.
Im Stöckach 22

D-70839 Gerlingen

Phone : +49 / (0)7156 / 177 42 62

Fax : +49 / (0)7156 / 177 42 64

eMail : info@speedART.de

www.speedart.de

HRA 721078

Place of jurisdiction Ludwigsburg

Owner Björn Striening

All brands, brand names and logos are property of their respective owners.

Changes reserved



Conversion program for Porsche 958 Cayenne
March 2013

Further informations about the navigation:



Interactive buttons and hyperlinks in the content overview to the right.



By clicking this symbol in the menu (product pages) you will get to the previous page.



By clicking this symbol in the menu (product pages) you will get to the next page.



By clicking this symbol in the menu (product pages) you will get to the content overview page.



By clicking this symbol in the menu (product pages) you can write us an email.



Article with TÜV technical approval.



Article with vehicle type approval.



New article.



Video- and sound files are opening in a new window by clicking on this symbol.

24:00

Estimated time for the conversion between delivery and collection. Only for stock articles. (hours:minutes)

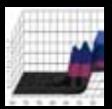

Dyno sheet files are opening in a new window by clicking on this symbol.



Conversion program for Porsche 958 Cayenne

Aerodynamic

Aerodynamic program TITAN-EVO	11
Aerodynamic program TITAN-EVO-XL	18
Aerodynamic program TITAN-IMPRESSION	23

Suspension

Suspension program	25
--------------------	----

Brakes

Brakes program	27
----------------	----

Wheels

Wheels program	28
----------------	----

Engine / Sport exhaust systems

Cayenne Diesel program	50
Cayenne Diesel S V8 program	53
Cayenne V6 program	54
Cayenne S / Hybrid program	56
Cayenne Turbo program	60

Interior

Interior program	65
------------------	----



lap time record TITAN-BTR 550, 1.50,6 min.



Oschersleben

Autobild Sportscars - 08/2008



1. place TITAN-BTR 550, 1.16,1 min.



Hockenheim

Tuner Grand Prix 2008



1. place TITAN-BTR 520, 1.17,1 min.



Hockenheim

Tuner Grand Prix 2007





„In the beginning it was just one thought“

The idea: to generate and design individuality in combination with performance. In a branch where is no space for mistakes to set up a product and a brand which has never been there before.

The purposes: from the beginning clearly defined! Exclusivity, precision and quality. Every vehicle is a hand crafted masterpiece with character.

Since the foundation in 1999, *speedART* has pursued a logical strategy of growth and progress. By a narrow collaboration with our developing partners from the most different technology regions in Germany and worldwide, the combination of traditional craftsmanship and the modern production procedure is also assured for the future.

Results? Our biggest success is if you express the enthusiasm for your car with a smile.

Everything that counts: perfect evolution! To go a step further without losing the aims out of sight. That is our task.

„You have to try the impossible, to reach the possible.“
Hermann Hesse





TITAN-EVO

A superlative car needs a superlative name.

The TITAN-EVO is a combination of a vehicle suited for everyday driving and sportscar for the race track which unites agility and driving dynamic as well as aesthetics and functionality with each other.

All this together makes the TITAN-EVO to

an unmistakeable experience of a quite special kind. The vehicles do not originate simply somewhere, they become true in exactly the same region where also the headquarter of the company PORSCHE lies namely between Zuffenhausen and Weissach in Rutesheim.

This is the place where the vehicles in craft master work are getting improved. This new headquarter of *speedART* since

the end of 2007 is the result of the logical conversion of strategy and growth. On about 2700m² originates here one of the most exciting sportscars in the world. Beside the TITAN-BTR-XL, hand-picked specialists from the most different areas assemble here the various vehicles.

„Thinking and being are determined by the contradiction.“
Aristoteles

TITAN-EVO



Unique design paired with innovative technology.

The performance of the *speedART* TITAN-EVO is overwhelmed. The rear diffuser, front spoiler, wide fender flares and side skirts, as well as the double tail pipes will be symbols for its high performance and dynamic.

The central theme of the exciting design of the vehicle refers to the whole bodywork composition and demonstrates dominance in the purest of forms. The *speedART* TITAN-EVO as *speed-HYBRID* shows that the driving performance of SUVs is comparably with sports cars. And this partially with zero-emission!

A new sport exhaust with sound control affords the possibility to choose between 2 sound levels: sportive and sonorous and discreet.

In summary: The TITAN-EVO celebrates an opus of power, agility and driving pleasure with characteristic sound.

The amazing sound comes from a completely new exhaust system with sound switch control. It can be chosen between constantly loud, constantly quiet or controlled by speed.

On the point: the TITAN-EVO celebrates a firework of power, agility and driving pleasure with a beguiling sound.

„Who wants to interest, must provoke.“
Salvador Dali







TITAN EVO-XL 580

SPEEDART





Aerodynamic TITAN-EVO

Aerodynamic TITAN-EVO



04:00



Front chin spoiler TITAN-EVO for Cayenne Diesel, V6, S, Hybrid

TITAN EVO front chin spoiler for fitting at the original front bumper for a sportive look and an improved brake cooling

Painting and fitting

Art. Nr.: P58.170.050.010
Art. Nr.: P58.170.050.010UM



04:00



Front chin spoiler TITAN-EVO for Cayenne Turbo

TITAN EVO front chin spoiler for fitting at the original front bumper for a sportive look and an improved brake cooling

Painting and fitting

Art. Nr.: P58.170.050.010
Art. Nr.: P58.170.050.010UM

06:00



Turbo-Look front 958 for Cayenne Diesel, V6, S, Hybrid

Conversion for Cayenne Diesel, V6, S, Hybrid, (Model 2011) with Turbo-Look-Frontbumper

Painting and fitting

Art. Nr.: P58.170.055.010
Art. Nr.: P58.170.055.010UM

Aerodynamic TITAN-EVO



02:00



Headlight covers TITAN-EVO

Headlight covers TITAN-EVO made of ABS-plastic

Painting and fitting

Art. Nr.: P58.170.050.020
Art. Nr.: P58.170.050.020UM



04:00



Rear diffuser TITAN-EVO for Cayenne Diesel, V6, S, Hybrid, Turbo

TITAN EVO rear diffuser for fitting at the original rear skirt for more downforce and a sportive look (trailer hitch compatible)

Painting and fitting

Art. Nr.: P58.170.050.050
Art. Nr.: P58.170.050.050UM



120:00



TITAN EVO Aerokit

TITAN EVO front chin spoiler for fitting at the original front bumper and TITAN EVO rear diffuser for fitting at the original rear skirt for more downforce and a sportive look (trailer hitch incompatible)

Painting and fitting

Art. Nr.: P58.170.080.010
Art. Nr.: P58.170.080.010UM

Aerodynamic TITAN-EVO



02:00

Rearlight cover TITAN-EVO

TITAN EVO rearlight cover for fitting at the original 958 Cayenne rear lights for a sportive look, 4-pieces

Painting and fitting

Art. Nr.: P58.170.050.055
Art. Nr.: P58.170.050.055UM





Aerodynamic Carbon

Aerodynamic Carbon



02:00



Front Spoiler Carbon

Front spoiler TITAN-EVO in Carbon, surface shiny or matt, for fitting at the original front bumper

Painting and fitting

Art. Nr.: PP58.370.050.010
Art. Nr.: P58.370.050.010UM

02:00



Rear diffuser Carbon

TITAN-EVO rear diffuser in Carbon, surface shiny or matt, for fitting at the original rear skirt (trailer hitch compatible)

Painting and fitting

Art. Nr.: PP58.370.050.010
Art. Nr.: P58.370.050.010UM

01:00



Side-Mirrors Carbon

Side-Mirrors in Carbon black, surface shiny or matt, per request all colors available, parts in exchange

Painting and fitting

Art. Nr.: P58.370.050.010
Art. Nr.: P58.370.050.010UM

Aerodynamic Carbon



02:00



Headlight covers Carbon

Headlight covers TITAN-EVO in Carbon, surface shiny or matt

Painting and fitting

Art. Nr.: PP58.370.050.010
Art. Nr.: P58.370.050.010UM

Rearlight cover Carbon

TITAN EVO rearlight cover for fitting at the original 958 Cayenne rear lights, surface shiny or matt, 4-pieces

Painting and fitting

Art. Nr.: PP58.370.050.010
Art. Nr.: P58.370.050.010UM

02:00





Aerodynamic TITAN-EVO-XL

Aerodynamic TITAN-EVO-XL



120:00

TITAN-EVO-XL Aerokit

TITAN EVO front chin spoiler for fitting at the original front bumper, TITAN EVO rear diffuser for fitting at the original rear skirt (trailer hitch incompatible), wide fender flares with integrated front mask and integrated rear outlet blend, door cover in the front and rear with integrated side skirts. Only for vehicles with Turbo-Look-Frontbumper

Painting and fitting

Art. Nr.: P58.170.080.020
Art. Nr.: P58.170.080.020UM





Aerodynamic TITAN-IMPRESSSION





Aerodynamic TITAN-IMPRESSSION



120:00



TITAN-IMPRESSSION Aerokit

TITAN IMPRESSSION Aerokit consists of front bumper, rear bumper (trailer hitch compatible), wide fender flares, door cover in the front and rear with integrated side skirts and complete new engine hood.

Painting and fitting

Art. Nr.: P58.170.080.025
Art. Nr.: P58.170.080.025UM



8:00



TITAN-IMPRESSSION Engine hood

TITAN IMPRESSSION complete engine hood

Painting and fitting

Art. Nr.: P58.170.080.026
Art. Nr.: P58.170.080.026UM



Suspension

Optimum transmission, high cornering speed, controllable at the limits and a safe driveability.

Sportive or comfortable! We do the setup like you wish. Modern suspensions with active controlled systems are offering still an optimizing of driveability because the most series suspensions are a compromise of sportive and comfort. We can offer you various opportunities

from comfortable suspension to complete adjustable coilover systems.

A brilliant cooperation between our development partner and test drivers is setting us in the lucky position to go on moving the limits of driving physics in your favor.

„Faith to those who search the truth and doubt those who already have found.“
Andre Gide

Suspension



01:00



Lowering module 40mm for vehicles with air-ride system

Electronical lowering module for vehicles with airride-suspension, the vehicle can be lowered on front axle 40mm and on rear axle 30mm. All height levels are still available. Axles can additionally be adjusted separately (+/- 20mm), inclusive plug and play adapter.

Fitting

Art. Nr.: P58.360.002
Art. Nr.: P58.360.002UM



08:00



Sport springs for Cayenne S / V6 / Diesel / Hybrid without air-ride system

Sport springs for Cayenne S / V6 without air-ride system. Lowering about 40 mm for a more direct and more sportive driving dynamic

Survey and fitting

Art. Nr.: P58.340.001
Art. Nr.: P58.340.001UM



Brakes

From 62 to 0 mph faster than from 0 to 62 mph.

To secure safety by power improved vehicles, it is necessary to adapt the brakes the engine power. Like the suspension, the brakes also can be improved in different ways.

Sport brake systems up to race brake systems made of ceramic component

material. We can offer different opportunities and the right setup for your requirements. To get an maximum in brake performance all components like suspension, wheels and tires have to be attuned well. Different motorsport and hightech materials are taking place in here.

Together with our technology and developing partner we are trying to improve

the different systems and technics in security, reliability, performance and driving pleasure.

„Who says A must not say B. He can also recognise that A was wrong.“
Bertolt Brecht

Brakes



ABE

02:00

Stainless steel brake hoses

Stainless steel brake hoses. Reducing the fading effect during heavy braking

Fitting and brake fluid

Art. Nr.: P58.393.420.SFL
Art. Nr.: P58.393.420.SFLUM



Special paint brake calipers

Special paint of brake calipers
Color free to choose

Fitting and brake fluid

Art. Nr.: P97.351.001
Art. Nr.: P97.351.001UM

72:00



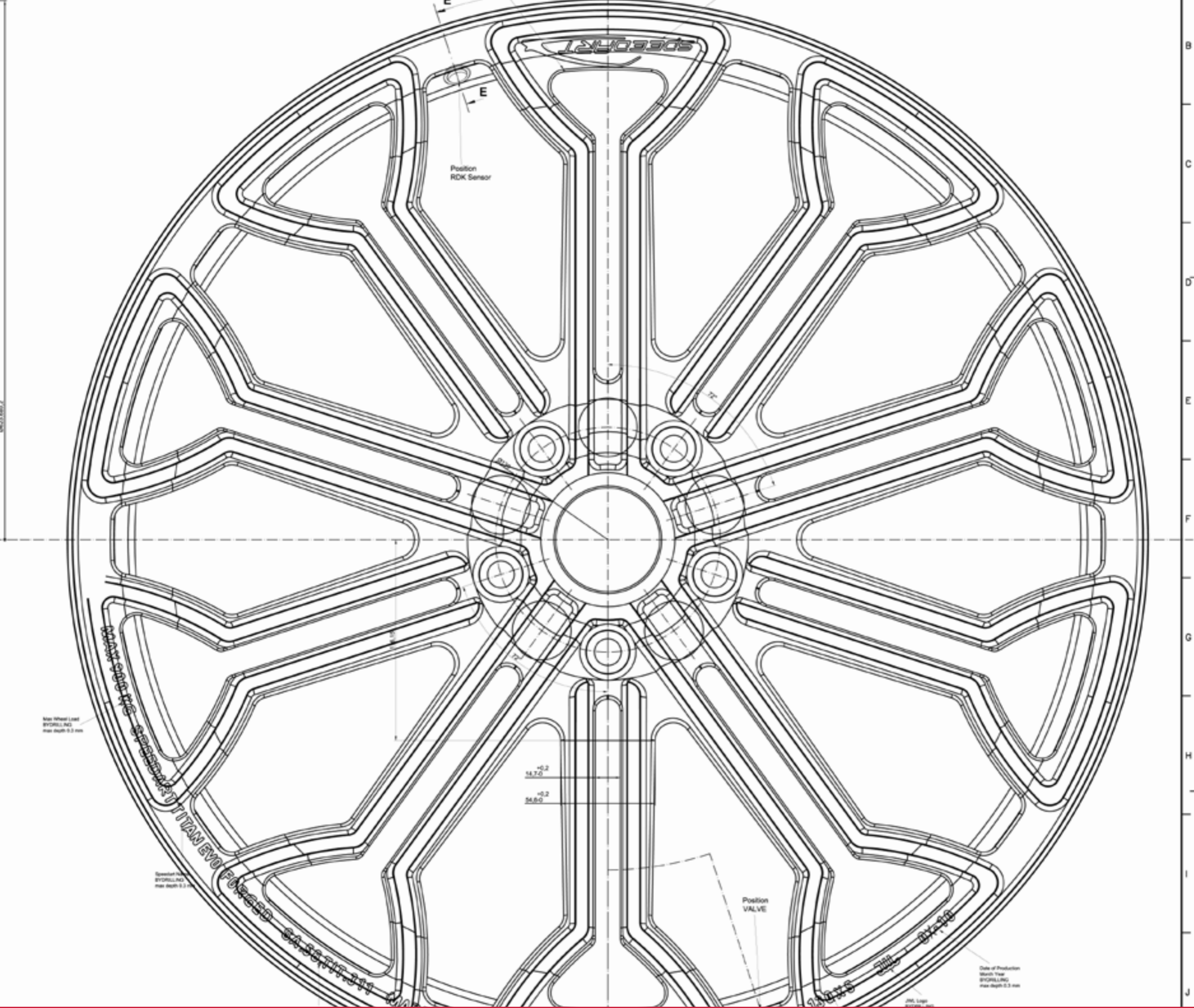
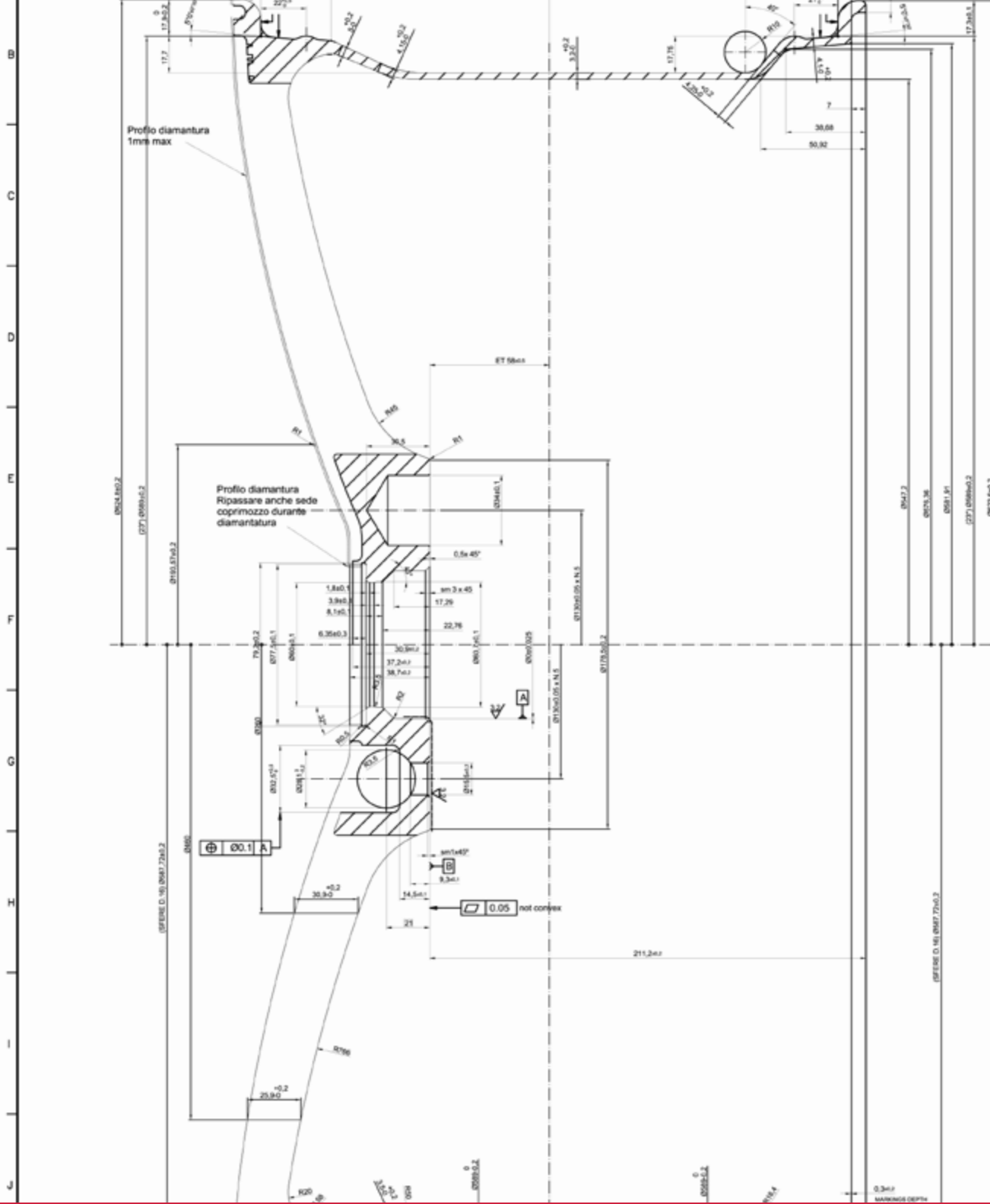

Wheels

Form follows function or reversed, just how you wish. Give your car an individual taste.

No matter if one piece forged or modular. Between different variants and types can be chosen.

Also we can offer individual paint jobs or powder coatings of wheel center, wheel lip and wheel bed in various colors. For

sportive and race driving we have weight reduced wheels in our product range.

Another enhancement in value you can reach with our harmonic wheel designs. Strong contours or smooth curves are creating a special and personal appearance of your car and highlight the claims of sportive elegance.

„The normality is a paved street, you can go well on it, however, there grow no flowers on her.“
Vincent van Gogh



Light Spoke Competition - FORGED 22"





LSC - FORGED 22"



LSC - FORGED wheel front axle

LSC - FORGED wheel, 3-piece screwed, forged center
Front axle: 9,5 x 22"

Art. Nr.: P11.LSC.110.010



LSC - FORGED wheel rear axle

LSC - FORGED wheel, 3-piece screwed, forged center
Rear axle: 11 x 22"

Art. Nr.: P11.LSC.110.020



LSC - FORGED wheelset inclusive tires

LSC - FORGED wheelset, 3-piece screwed, forged center
FA: 9,5 x 22" with 275/35 ZR22, RA: 11 x 22" with 315/30 ZR22
Tire: Continental Sport Contact

Art. Nr.: P11.LSC.210.CAY

LSC - FORGED 22"



LSC - FORGED wheelset inclusive tires

LSC - FORGED wheelset, 3-piece screwed, forged center
FA: 11 x 22" with 315/30 ZR22, RA: 11 x 22" with 315/30 ZR22
Tire: Continental Sport Contact

Art. Nr.: P11.LSC.210.CA2



Special color

Special color for LSC center star

Art. Nr.: P11.LSC.310.020



RDK - Tire pressure control

RDK-Sensors for series tire pressure control
Mind the region code in MHZ

Art. Nr.: P11.LSC.RDK.040





CTS - Challenge Twin Spoke - FORGED 22"

1-piece monobloc forged

CTS - FORGED 22"



CTS-FORGED wheel front / rear axle

CTS-FORGED wheel, 1-piece forged, bicolor black/silver or silver
Front / rear axle: 10 x 22"

Art. Nr.: S23.CTS.958C



CTS-FORGED wheelset inclusive tires

CTS-FORGED wheelset, 1-piece forged, bicolor black/silver or silver
10 x 22" with 295/30 ZR22,
Tires: Michelin or Continental

Art. Nr.: S23.CTS.RSC

01:00



RDK - Tire pressure control

RDK-Sensors for series tire pressure control
Mind the region code in MHZ

Art. Nr.: P11.1220.RDK





Challenge Twin Spoke - FORGED 23"

1-piece monobloc forged, weight only 16,4 kg

CTS - FORGED 23"



CTS-FORGED wheel front / rear axle

CTS-FORGED wheel, 1-piece forged, bicolor black/silver or silver
Front / rear axle: 11 x 23"

Art. Nr.: S23.CTS.958



01:00



CTS-FORGED wheelset inclusive tires

CTS-FORGED wheelset, 1-piece forged, bicolor black/silver or silver
FA: 11 x 23" with 315/25 ZR23, RA: 11 x 23" with 315/25 ZR23
Tire: Michelin Latitude Sport

Art. Nr.: S23.CTS.RSM

RDK - Tire pressure control

RDK-Sensors for series tire pressure control
Mind the region code in MHZ

Art. Nr.: P11.1220.RDK





Cross Racing Mono 22"

1-piece monobloc casted, modular look

Cross Racing Mono 22"



Cross Racing Mono wheel front / rear axle

Cross Racing Mono wheel front / rear axle, 1-piece casted, modular look, silver or black matt

Front / rear axle: 10x22" ET 41 or ET 60

Art. Nr.: P55.362.080



01:00



Cross Racing Mono wheelset

Cross Racing Mono wheelset, 1-piece casted, modular look, silver or black matt

FA+RA: 10x22" ET41 or 60 with 295/30 ZR22

Art. Nr.: P55.360.090



RDK - Tire pressure control

RDK-Sensors for series tire pressure control
Mind the region code in MHZ

Art. Nr.: P11.1220.RDK



FSC- Five Spoke Competition 22"

FSC 22"



FSC wheel front axle

FSC- Five Spoke Competition wheel, 1-piece
Size: 9 x 22" ET 48

Art. Nr.: PF22.FSC.100.010



FSC wheel rear axle

FSC- Five Spoke Competition wheel, 1-piece
Size: 10,5 x 22" ET 55"

Art. Nr.: F22.FSC.100.020



01:00



FSC wheelset

FSC- Five Spoke Competition wheelset, 1-piece
FA+RA: 10,5 x 22" ET 55 mit 295/30 ZR22
Tires Continental Sport Contact 3

Art. Nr.: R22.FSC.100.010CAY

FSC 22"



Special color

Special color for FSC wheel

Art. Nr.: R22.FSC.300.010



RDK - Tire pressure control

RDK-Sensors for series tire pressure control
Mind the region code in MHZ

Art. Nr.: P11.LSC.RDK.040





Sport Terrain 22"

1-piece monobloc casted

Sport Terrain 22"



Sport Terrain wheel front / rear axle

Sport Terrain wheel, 1-piece casted
Front / rear axle: 10 x 22"

Art. Nr.: P55.STF.122



01:00



Sport Terrain wheelset inclusive tires

Sport Terrain wheelset, 1-piece casted
FA: 10 x 22" with 295/30 ZR22, RA: 10 x 22" with 295/30 ZR22
Tire: Continental Cross Contact

Art. Nr.: P55.STR.295

RDK - Tire pressure control

RDK-Sensors for series tire pressure control
Mind the region code in MHZ

Art. Nr.: P11.1220.RDK





Star-Racing 20"

1-piece monobloc casted

Star-Racing 20"



Star-Racing wheel front / rear axle

Star-Racing wheel, 1-piece casted
Front / rear axle: 10 x 20"

Art. Nr.: P55.362.SE1020



01:00



Star-Racing wheelset inclusive tires

Star-Racing wheelset, 1-piece casted
FA: 10 x 20" with 295/40 ZR20, RA: 10 x 20" with 295/40 ZR20
Tire: Michelin Diamaris or Continental Cross Contact

Art. Nr.: P55.360.1020

RDK - Tire pressure control

RDK-Sensors for series tire pressure control
Mind the region code in MHZ

Art. Nr.: P11.1220.RDK





Star-Racing 22"

1-piece monobloc casted

Star-Racing 22"



Star-Racing wheel front / rear axle

Star-Racing wheel, 1-piece casted
Front / rear axle: 10 x 22"

Art. Nr.: P55.362.SE001



01:00



Star-Racing wheelset inclusive tires

Star-Racing wheelset, 1-piece casted
FA: 10 x 22" with 295/30 ZR22, RA: 10 x 22" with 295/30 ZR22
Tire: Michelin Diamaris or Continental Cross Contact

Art. Nr.: P55.360.SE001

RDK - Tire pressure control

RDK-Sensors for series tire pressure control
Mind the region code in MHZ

Art. Nr.: P11.1220.RDK





Engine / Sport exhaust systems

Power increase based on the newest standards of technics and on top of the happening.

Power in every situation, is brought to the TITAN-EVO.

All components like gearbox, clutch and engine are so attuned that at every time the maximum power is available. In co-operation with aerodynamic, suspensi-

on, wheels, tires and brakes it creates an amazing value of driving dynamic.

„The whole thing is more than the sum of its parts.“
Aristoteles

Engine Cayenne Diesel



00:30



Sport air filter

Sport air filter

Fitting

Art. Nr.: P58.520.010.V6
Art. Nr.: P58.520.010.V6UM

Sport twin tailpipes

twin tailpipes 2 x 100 mm for original exhaust or *speedART* sport exhaust (fits original rear skirt lower value), made of stainless steel

Fitting

Art. Nr.: P58.684.080.005
Art. Nr.: P58.684.080.005UM

01:00



Sport exhaust for original tailpipes

Sport exhaust for OE tail pipes or *speedART* twin tailpipes for more sportive sound
Made of stainless steel, EU- or Export-Sound

Fitting

Art. Nr.: P58.684.080.010
Art. Nr.: P58.684.080.010UM

02:30



Engine Cayenne Diesel



08:00



Soundmodul Cayenne Diesel

Electronic soundmodul with loudspeakers

Fitting

Art. Nr.: P58.684.080.SOM
Art. Nr.: P58.684.080.SOMUM

Powerkit I 275 hp / 600 Nm

Powerkit I
Motronic-Update for 275 hp / 600 Nm with additional ECU, inclusive cable set

Fitting

Art. Nr.: P58.640.070.010
Art. Nr.: P58.640.070.010UM

00:30



Engine Cayenne Diesel



00:30

Powerkit II 285 hp / 610 Nm

Powerkit II
Motronic-Update for 285 hp / 610 Nm with additional ECU, inclusive cable set

Fitting

Art. Nr.: P58.640.070.020
Art. Nr.: P58.640.070.020UM



Image similar

Powerkit III 290 hp / 640 Nm

Powerkit III
Motronic-Update for 290 hp / 640 Nm with modified ECU

Fitting

Art. Nr.: P58.640.070.030
Art. Nr.: P58.640.070.030UM

01:00



Engine Cayenne Diesel S V8



01:00

Sport air filter

Sport air filter

Fitting

Art. Nr.: P58.520.010.V8
Art. Nr.: P58.520.010.V8UM



Powerkit I 425 hp / 920 Nm

Powerkit I
Motronic-Update for 425 hp / 920 Nm with additional ECU, inclusive cable set

Fitting

Art. Nr.: P58.640.070.SV8
Art. Nr.: P58.640.070.SV8UM



01:00



Engine Cayenne V6



00:30



Sport air filter

Sport air filter

Fitting

Art. Nr.: P58.520.010.V6
Art. Nr.: P58.520.010.V6UM

Sport twin tailpipes

twin tailpipes 2 x 100 mm for original exhaust or *speedART* sport exhaust (fits original rear skirt lower value), made of stainless steel

Fitting

Art. Nr.: P58.680.080.005
Art. Nr.: P58.680.080.005UM

01:00



Sport exhaust

Sport exhaust with 2 x 100mm twin tailpipes in stainless steel polished, for sportive sound in combination with a power improvement by reduced exhaust gas back pressure, made of stainless steel, EU- or Export-Sound

Fitting

Art. Nr.: P58.680.080.020
Art. Nr.: P58.680.080.020UM

02:30



Engine Cayenne V6



02:30

Sport exhaust titanium

Sport exhaust with 2 x 100mm twin tailpipes, made of titanium
EU- or Export-Sound, weight 10.8kg (Standard 20.1kg)

Fitting

Art. Nr.: P58.680.080.030
Art. Nr.: P58.680.080.030UM



Sport exhaust with sound control

Sport exhaust with sound control with 2 x 100mm twin tailpipes in stainless steel polished,
for sportive sound in combination with a power improvement by reduced exhaust gas back
pressure, made of stainless steel, EU- or Export-Sound

Fitting

Art. Nr.: P58.680.080.040
Art. Nr.: P58.680.080.040UM

08:00

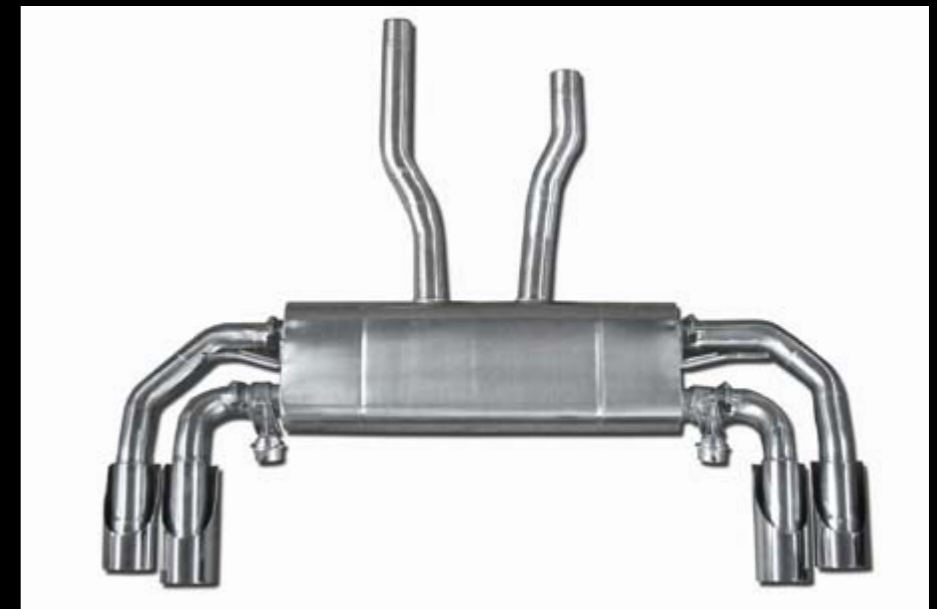

[Image similar](#)

Engine Cayenne S



00:30

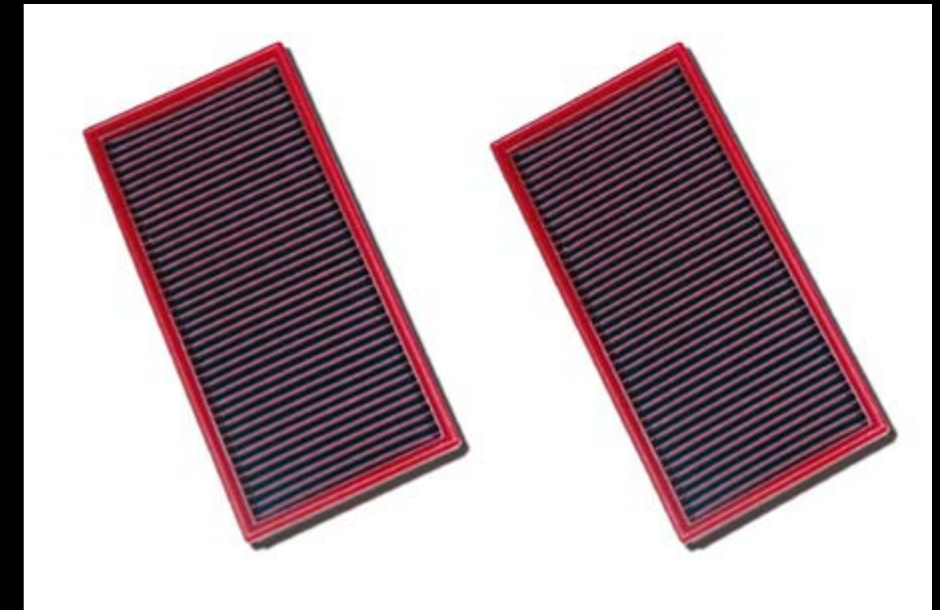

Sport air filter

Sport air filter

Fitting

Art. Nr.: P58.520.010.V8
Art. Nr.: P58.520.010.V8UM

Sport twin tailpipes

twin tailpipes 2 x 100 mm for original exhaust or *speedART* sport exhaust (fits original rear skirt lower value), made of stainless steel

Fitting

Art. Nr.: P58.682.080.005
Art. Nr.: P58.682.080.005UM

01:00



Sport exhaust

Sport exhaust with 2 x 100mm twin tailpipes in stainless steel polished, for sportive sound in combination with a power improvement by reduced exhaust gas back pressure, made of stainless steel, EU- or Export-Sound

Fitting

Art. Nr.: P58.682.080.020
Art. Nr.: P58.682.080.020UM

02:30



Engine Cayenne S



02:30

Sport exhaust titanium

Sport exhaust with 2 x 100mm twin tailpipes, made of titanium
EU- or Export-Sound, weight 10.8kg (Standard 20.1kg)

Fitting

Art. Nr.: P58.682.080.030
Art. Nr.: P58.682.080.030UM



Sport exhaust with sound control

Sport exhaust with sound control with 2 x 100mm twin tailpipes in stainless steel polished,
for sportive sound in combination with a power improvement by reduced exhaust gas back
pressure, made of stainless steel, EU- or Export-Sound

Fitting

Art. Nr.: P58.682.080.040
Art. Nr.: P58.682.080.040UM

08:00

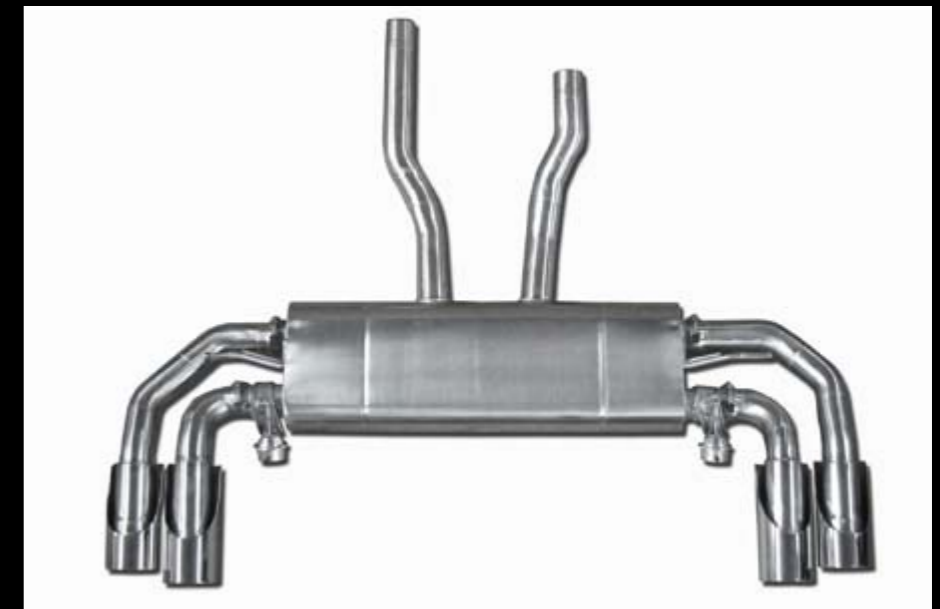

Image similar

Engine Cayenne S Hybrid



00:30



Sport air filter

Sport air filter

Fitting

Art. Nr.: P58.520.010.V6
Art. Nr.: P58.520.010.V6UM

Sport twin tailpipes

twin tailpipes 2 x 100 mm for original exhaust or *speedART* sport exhaust (fits original rear skirt lower value), made of stainless steel

Fitting

Art. Nr.: P58.683.080.005
Art. Nr.: P58.683.080.005UM

01:00



Sport exhaust

Sport exhaust with 2 x 100mm twin tailpipes in stainless steel polished, for sportive sound in combination with a power improvement by reduced exhaust gas back pressure, made of stainless steel, EU- for Export-Sound

Fitting

Art. Nr.: P58.683.080.020
Art. Nr.: P58.683.080.020UM

02:30



Engine Cayenne S Hybrid



02:30

Sport exhaust titanium

Sport exhaust with 2 x 100mm twin tailpipes, made of titanium
EU- or Export-Sound, weight 10.8kg (Standard 20.1kg)

Fitting

Art. Nr.: P58.683.080.030
Art. Nr.: P58.683.080.030UM



Sport exhaust with sound control

Sport-exhaust with sound control with 2 x 100mm twin tailpipes surface stainless steel polished, EU- or Export-Sound, for vehicles without original sound switch exhaust, includes the conversion to control the sound switch via separate switch button.

Fitting

Art. Nr.: P58.683.080.040
Art. Nr.: P58.683.080.040UM

08:00

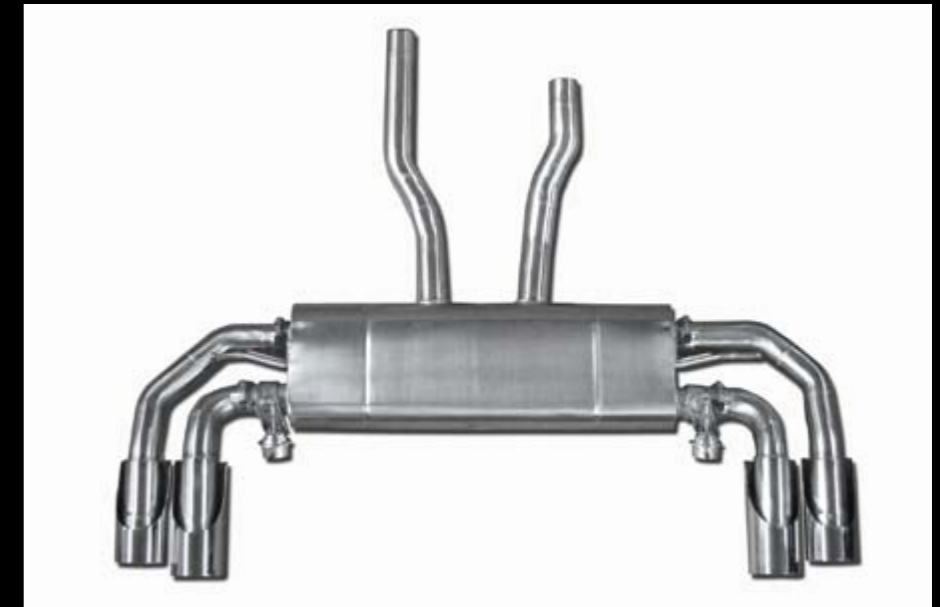

Image similar

Powerkit I 450 hp / 570 Nm

Powerkit I
Motronic-Update for 450 hp / 570 Nm with additional ECU, inclusive cable set

Fitting

Art. Nr.: P58.750.050.010
Art. Nr.: P58.750.050.010UM



01:00



Engine Cayenne Turbo



00:30

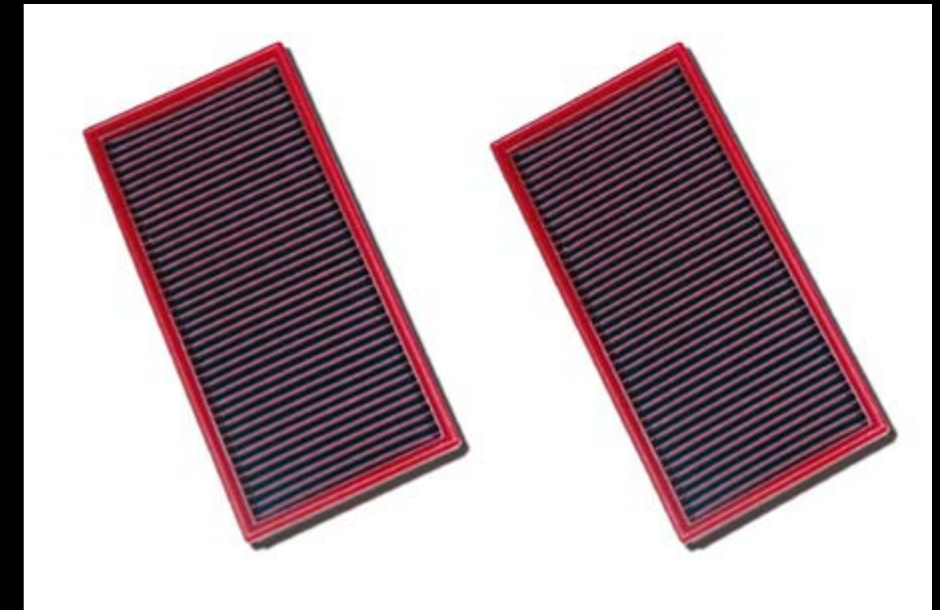

Sport air filter

Sport air filter

Fitting

Art. Nr.: P58.520.010.V8
Art. Nr.: P58.520.010.V8UM

01:00



Sport twin tailpipes

twin tailpipes 2 x 100 mm for original exhaust or *speedART* sport exhaust (fits original rear skirt lower value), made of stainless steel

Fitting

Art. Nr.: P58.681.080.005
Art. Nr.: P58.681.080.005UM

02:00



Catalyst cross pipes

Catalyst cross pipes

Fitting

Art. Nr.: P58.681.081.010
Art. Nr.: P58.681.081.010UM

Engine Cayenne Turbo



02:30

Sport exhaust

Sport exhaust with 2 x 100mm twin tailpipes in stainless steel polished, for sportive sound in combination with a power improvement by reduced exhaust gas back pressure, made of stainless steel, EU- or Export-Sound

Fitting

Art. Nr.: P58.681.080.020
Art. Nr.: P58.681.080.020UM



[Image similar](#)

02:30

Sport exhaust titanium

Sport exhaust with 2 x 100mm twin tailpipes, made of titanium EU- or Export-Sound, weight 10.8kg (Standard 20.1kg)

Fitting

Art. Nr.: P58.681.080.030
Art. Nr.: P58.681.080.030UM



08:00

Sport exhaust with sound control

Sport exhaust with sound control with 2 x 100mm twin tailpipes in stainless steel polished, for sportive sound in combination with a power improvement by reduced exhaust gas back pressure, made of stainless steel, EU- or Export-Sound

Fitting

Art. Nr.: P58.681.080.040
Art. Nr.: P58.681.080.040UM

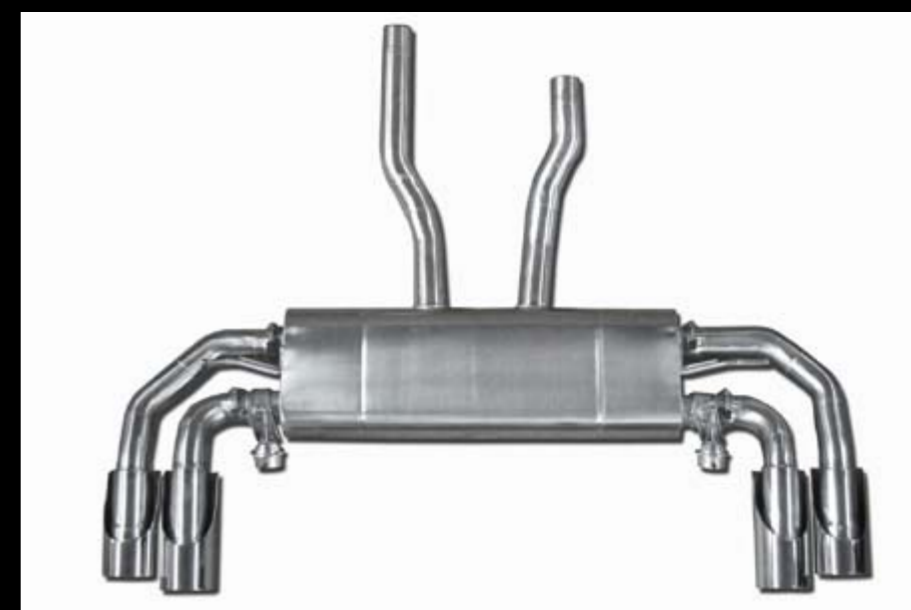

Engine Cayenne Turbo



03:00

Dyno performance test

Entry and exit dyno performance test (4-wheel) to detect effective performance
Appointment necessary

Art. Nr.: PXX.250.001



Engine Cayenne Turbo



02:00



Powerkit I 560+ hp / 790 Nm

Powerkit I with about 560+ hp and 790 Nm for 958 Turbo with additional ECU

Fitting

Art. Nr.: P58.750.060.000
Art. Nr.: P58.750.060.000UM

08:00



Powerkit II 580 hp / 820 Nm

Powerkit II with about 580 hp and 820 Nm for 958 Turbo with additional ECU, sport-exhaust with 4 x 100mm tailpipes, made of stainless steel, catalyst cross-pipes (rear catalyst), sport air filter, EU- or Export-Sound

Fitting

Art. Nr.: P58.750.060.010
Art. Nr.: P58.750.060.010UM

08:00



Powerkit II 580 hp / 820 Nm titanium

Powerkit II with about 580 hp and 820 Nm for 958 Turbo with additional ECU, sport-exhaust with 4 x 100mm tailpipes, made of Titanium, catalyst cross-pipes (rear catalyst), sport air filter, EU- or Export-Sound

Fitting

Art. Nr.: P58.750.060.015
Art. Nr.: P58.750.060.015UM

Engine Cayenne Turbo



08:00

Powerkit II 580 hp / 820 Nm sport exhaust with sound control

Powerkit II with about 580 hp and 820 Nm for 958 Turbo with additional ECU, sport-exhaust with sound control with 4 x 100mm tailpipes, made of stainless steel, catalyst cross-pipes (rear catalyst), sport air filter, EU- or Export-Sound

Fitting

Art. Nr.: P58.750.060.030
Art. Nr.: P58.750.060.030UM

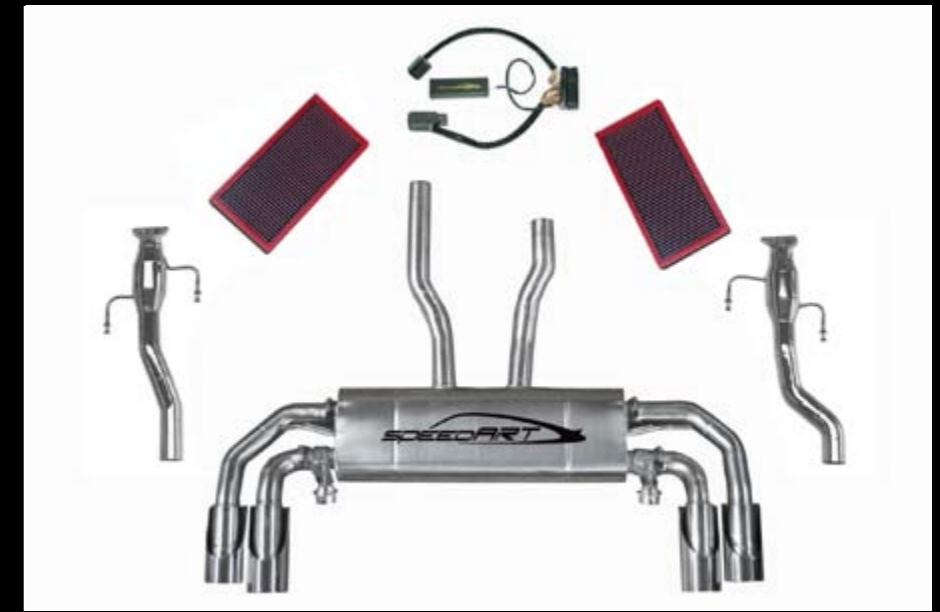



Interior

Fabric, leather and microfiber and also carbon, stainless steel, aluminium and wood. In combination with entertainment and multimedia. Various forms and colors in any thinkable version.

Also here the best materials are used and technology on the newest state of the things. No matter whether tone in tone, Bi-color or a mix from the respective materials, in creating the interior the-

re are nearly no borders placed. In the course of the years all this only became possible by an intensive collaboration with the most different companies who have specialized themselves in individualizing interiors.

Here it is exclusively pure manual labour and the standards in quality and processing are exceptionally high. Please notice that a listing of all products and

variations in the interior is in this prospect not possible because of the large amount of opportunities.

Please send us your enquiry direct to info@speedART.de. We will send you as soon as possible our response and a detailed offer.

„Temptations you should give in. Who knows if they come back!“
Oscar Wilde

Interior



24:00



Instrument dials

Instrument dials for all Cayenne models, color of the instrument dials freely selectable, *speedART* Logo

Fitting

Art. Nr.: P58.450.310.010
Art. Nr.: P58.450.310.010UM

Aluminium pedal set for manual gearbox

4-pieces: foot rest, gas pedal, clutch and brake in aluminium

Fitting

Art. Nr.: P58.950.310.010
Art. Nr.: P58.950.310.010UM

01:00



Image similar

Aluminium pedal set for TIPTRONIC

3-pieces: foot rest, gas pedal and brake in aluminium

Fitting

Art. Nr.: P58.950.310.011
Art. Nr.: P58.950.310.011UM

01:00



Interior



02:00



Turbo pressure gauge for Cayenne Diesel and Turbo

Turbo pressure gauge illuminated 2.0 bar, covered with leather and ready for plug and play fitting, inclusive assembly kit, color and leather freely selectable

Fitting

Art. Nr.: P58.330.001D
Art. Nr.: P58.330.001DUM

Colored safety seat belts

Colored safety seat belt

Fitting

Art. Nr.: P58.500.310.010
Art. Nr.: P58.500.310.010UM

08:00



Floor mats

Floor mats with *speedART* logo, color freely selectable

Art. Nr.: P58.950.310.090



Interior



240:00



[picture similar](#)

Leather package 1

Leather package 1, contains: seats inclusive arm rest, instrument panel upper section, center console, door panels upper section (breast wall), door panel arm rest color and leather freely selectable

Inclusive fitting

Art. Nr.: P58.551.001UM

240:00



[picture similar](#)

Leather package 2

Leather package 2, contains leather package 1 plus: instrument panel lower section, door panels (door handles, plain surfaces), entrance blends, pillar casing lower section, fond casing (trunk), seat casing, color and leather freely selectable

Inclusive fitting

Art. Nr.: P58.551.002UM

240:00



[picture similar](#)

Leather package 3

Leather package 3, contains leather package 1 and 2 plus: complete roof, pillar casing upper section, sun visors, carpet complete, color of carpet and leather freely selectable

Inclusive fitting

Art. Nr.: P58.551.003UM

Interior



120:00



Stitching package

Stitching package, contains: seats inclusive arm rest, instrument panel upper section, center console, door panels upper section (breast wall), color freely selectable

Inclusive fitting

Art. Nr.: P58.551.011UM

120:00



Single seats front multimedia

Single seats front and rear inclusive center console for Multimedia Consists of: sport seats with carbon back cover, fitting brackets for sport seats, center console rear for Multimedia, bracket for iPad, Dockingstation for iPad, Dockingstation for iPhone

Inclusive fitting

Art. Nr.: P58.950.320.010UM

8:00



iPad mount

iPad mount for 958 Cayenne

fitting

Art. Nr.: P58.330.001MM
Art. Nr.: P58.330.001MMUM



TITAN EVO-XL 600

SPEEDART